

TFL Serious Truss Serious Light Duty

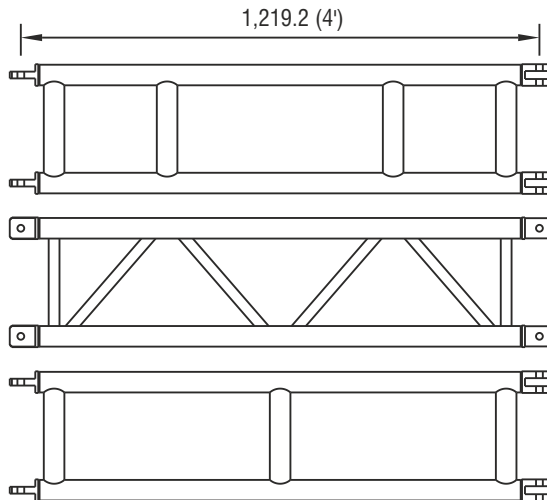

Serious Light Duty Truss has the same overall dimensions as Generic Light Duty Truss, but offers even greater load carrying capacities and spans than the original. The use of thicker chords and diagonals increases the bending and shear strength of the truss which is offered with Fork End connectors as standard.

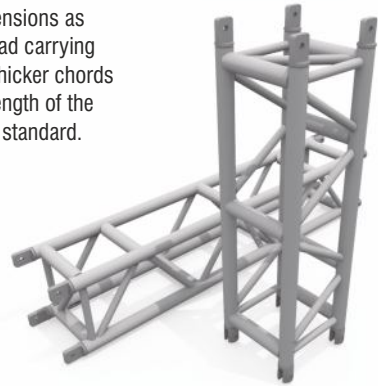
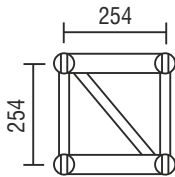

TFL Serious Truss Serious Light Duty



Load Table

Span (metres)		2	4	6	8	10	12	14	16
UDL	kg	2978	2956	2397	1759	1367	1099	901	747
DEFL	mm	1	9	24	41	63	87	113	140
CPL	kg	2378	1825	1199	880	684	549	450	373
DEFL	mm	1	9	19	33	50	70	91	112
TPL	kg	2378	2356	1798	1319	1026	824	676	560
DEFL	mm	1	9	24	42	64	89	116	143
QPL	kg	2378	2356	1798	1319	1026	824	676	560
DEFL	mm	1	9	23	39	59	83	107	133

Connection: Fork fitting. Fixings: TFT truss pin and R3 R Clip

Third and Quarter point loads are displayed as a total load and NOT individual point loads.

Span (metres)		2
UDL	kg	1900
DEFL	mm	7.6
EPL	kg	950
DEFL	mm	9.4
CPL	kg	1900
DEFL	mm	6.3

Uniform Load
(UDL)

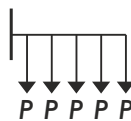

Point Load
(Edge)

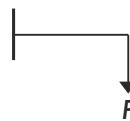

Point Load
(Central)

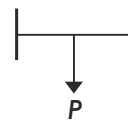

TFL Serious Truss Serious Light Duty



- All loads are given in kilograms and are total safe working loads (unfactored) at node points of a chord members only
- Allowance has been made for self-weight of the truss
- Allowance has been made for frequent use factor of 85%
- The payload on a truss has been calculated as a permanent action. Should it be necessary to consider the payload as a variable action, the tabulated figures should be reduced to 90% of the given values
- No allowance for dynamic loading has been made
- Capacity has been calculated in accordance with BS EN 1999 – Design of Aluminium Structures
- All loads applied are symmetrical between bottom 2 chords
- All deflections stated are theoretical deflections which do not account for any connection slippage. As such the values stated in these tables will be less than the actual deflection of the truss
- Care must be taken regarding the correct orientation of the bracing arrangement and support condition of the truss. The figures 1 and 2 show the acceptable orientations and supporting conditions of the truss and figures 3 and 4 show the orientation and support condition that should not be used.

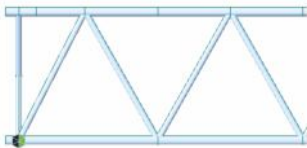

Figure 1: Orientation of the truss supported of bottom chords

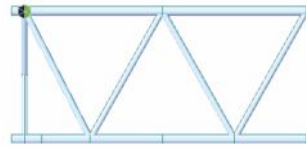

Figure 2: Orientation of the truss supported of top chords

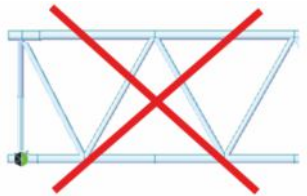

Figure 3: Not allowed orientation of the truss supported of bottom chords

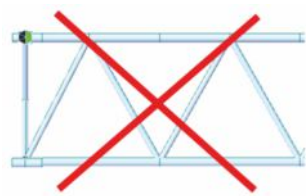

Figure 4: Not allowed orientation of the truss supported of top chords

TFL Serious Truss Serious Light Duty



Material Specifications

Main Cord:	48.44mm x 4.47mm
Braces:	25.44mm x 3.25mm
Material:	EN AW-6082 T6
Fixings:	Fork End : TFT pins & R3 Clips

Accessories

Circles
Angled Corners
Bespoke Lengths
Hinges and Swivels

Item Codes, Weights and Dimensions

SLD5F	Serious LD 5ft Truss Section	1576mm x 305mm x 305mm	17 kg
SLD8F	Serious LD 8ft Truss Section	2499mm x 305mm x 305mm	27 kg
SLD10F	Serious LD 10ft Truss Section	3100mm x 305mm x 305mm	32 kg
SLD1M	Serious LD 1M Truss Section	1026mm x 305mm x 305mm	12 kg
SLD2M	Serious LD 2M Truss Section	2026mm x 305mm x 305mm	22 kg
SLD3M	Serious LD 3M Truss Section	3026mm x 305mm x 305mm	32 kg
SLD4M	Serious LD 4M Truss Section	4026mm x 305mm x 305mm	42 kg
SLDC4M	Serious LD 4 Way Corner Section	465mm x 465mm x 325mm	17 kg

Design Specification

Manufactured in accordance with

BS EN 1090-3:2008 : Technical Requirements for aluminium structures

EN ISO 9001:2008 : Quality management systems

BS EN 1999 Pt 1-1 : Design of Aluminium Structures, General structural rules

EN17115: Entertainment Technology : Specifications for design, manufacture of aluminium and steel trusses and towers

